

# The Grand Coulee Dam

## US Army Corps of Engineers Selects RTI Messaging Middleware



The Grand Coulee Hydroelectric Gravity Dam on the Columbia River is an awesome sight to behold. In addition to its colossal physical dimensions—the dam being the single largest concrete structure—the powerhouse is the single largest electrical energy producer in the entire United States. Its massive powerhouse generates 6.8 gigawatts—3.5 times more than the Hoover Dam.

### The Problem

The Grand Coulee Dam must carefully control how it supplies power to the grid. Failures that cause power spikes or dropouts are not acceptable. Much of the Pacific Northwest is dependent on reliable energy supplied by the Grand Coulee, and power system disturbances which interrupt customer electricity (like the cascading power line failure incident which interrupted power to 7.5 million customers in 1996) can have catastrophic economic impact on the region.

### The Solution

Recognizing the need for modernization, a major initiative to retrofit the control system of the Grand Coulee Dam was begun by the US Department of the Interior's Bureau of Reclamation (BOR) in cooperation with the Bonneville Power Administration (BPA).

The dam network connects a 40,000 point SCADA system controlling 30 generators to a transmission switchyard.

The US Army Corps of Engineers selected RTI Data Distribution Service, a DDS-compliant software network infrastructure, for an upgrade of the Grand Coulee Dam. RTI middleware will integrate components of the next-generation Supervisory Control and Data Acquisition (SCADA) system, enabling more efficient and reliable hydroelectric power generation.

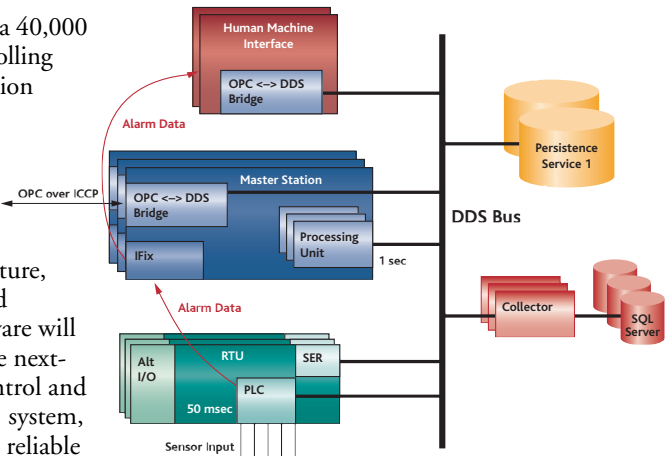

*“We selected RTI after a comprehensive evaluation of Data Distribution Service (DDS) solutions. We liked RTI’s architecture the best because it eliminates all single points of failure for superb reliability.”*

Dave Brown,  
Project Manager and System Architect,  
US Army Corps of Engineers

In the new architecture, RTI Data Distribution Service will be used to integrate 50 to 60 Linux-based Programmable Logic Controllers (PLCs) on the central control network along with Windows Human-Machine Interface (HMI) systems and various database and health-monitoring servers. The system will run on standard, ruggedized commercial computing hardware. The architecture will eventually be deployed on a network of 12 dams in the Federal Columbia River Power System.

The US Army Corps of Engineers Hydroelectric Design Center (HDC) is the system integrator; HDC selected RTI Data Distribution Service to implement a highly available, high-performance and scalable control system.

Dave Brown, the project manager and System Architect for the US Army Corps of Engineers said, “We selected RTI after a comprehensive evaluation of Data Distribution Service (DDS) solutions. We liked RTI’s architecture the best because it eliminates all single points of failure for superb reliability. Other implementations depend on centralized server or ‘daemon’ processes. If a shared daemon fails, it impacts many critical applications. With RTI’s purely in-process solution, there is no dependence on shared services. We will be able to implement N-way redundancy for all critical subsystems.” Brown continued, “RTI’s product was also the highest performance; it far exceeds our requirements. We also found the total cost of ownership lower than with other DDS options, even open-source implementations.”

Automated Control Systems Inc. (ACSI) is a contractor on the project. ACSI President Dan Perrier stated, “The dam control system processes waveform data, power metrics, temperatures, oil levels, vibration sensors and more. The current system uses many different protocols. DDS, with its flexible configuration and high performance, is easier to work with and is a better way to integrate the systems.”

### Why RTI Was Selected

- Easily handles demanding SCADA performance requirements
- Uses a high availability, peer-to-peer design with no single point of failure
- Simplifies programming and reaction to changes with its data-centric design
- Simplifies interfaces to databases and human interfaces
- Backed by field-proven results
- Based on the widely adopted and standards-based OMG DDS specification
- Provides fast system start up, with no dependency on the order of systems coming online
- Provides multiple additional services such as recording and persistence

### About RTI Data Distribution Service

RTI Data Distribution Service provides a messaging and integration infrastructure for demanding, mission-critical distributed applications. It combines deterministic performance, low latency, high throughput, and fault tolerance into a fast, scalable architecture for real-time systems. By enabling loosely coupled integration, it significantly reduces long-term software maintenance costs; individual subsystems may be modified, added, or upgraded without impacting existing software.

RTI Data Distribution Service complies with the Object Management Group (OMG) Data Distribution Service for Real-Time Systems (DDS), the leading standard for real-time application integration. RTI also natively supports the DDS Real-Time Publish-Subscribe (RTPS) wire protocol for peer-to-peer interoperability with other RTPS-compliant DDS implementations. RTI is the world’s leading supplier of DDS-related software and services.

### About RTI

Real-Time Innovations (RTI) provides high-performance infrastructure solutions for distributed real-time applications. RTI middleware delivers dramatic improvements in latency, throughput and scalability while slashing cost of ownership. A broad range of industries leverage RTI’s software and design expertise, including defense, intelligence, simulation, industrial control, power generation, transportation, finance, medical and communications. Founded in 1991, RTI is privately held and headquartered in Sunnyvale, California. For more information, please visit [www.rti.com](http://www.rti.com).